

Upper Liquid Level Gauge

Features

- Tri Clover ends 25.4-38.1mm
- Silicone seal maximum temperature rating 180°C
- Stainless steel retaining nuts
- Maximum pressure rating 145 PSI / 10 Bar
- Used with 19.05mm polycarbonate or borosilicate glass tube

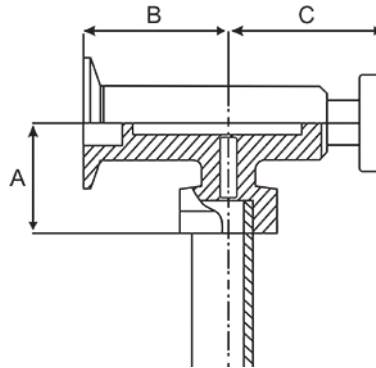

Unit: mm (unless stated otherwise)

Dimensions

Size	3/4" 19.05
A	55
B	48
C	55.5
Code	SLLGT20

