

NOTES

MATERIAL: STAINLESS STEEL
 GRADE: 304 & 316L
 DIMENSIONAL STANDARD: AS1528.3 : 2001
 SURFACE FINISH: EXTERNAL=320 GRIT, INTERNAL=ROUGHNESS NOT EXCEEDING 1.0µm Ra
 MANUFACTURING PROCESS: MADE FROM MATERIAL CONFORMING WITH ASTM A240M OR ASTM A269
 UOM: MILLIMETERS (mm)

SUPPLIER TO REMOVE AND/OR DEBUR ALL SHARP EDGES
 ERRORS AND OMISSIONS EXCEPTED

FEATURES

TO SUIT IMPERIAL SIZED TUBE
 LENGTH TOLERANCE = +0.50MM -0.00MM
 PERPENDICULARITY TOLERANCE = ASME B16.9
 PLEASE NOTE THAT STB420090S & STB620090S DO NOT MEET AS1528.3.
 AS THIS SIZE IS NOT COVERED IN THE STANDARD, THEY DO HOWEVER FOLLOW.
 SUIT WITH THE TREND FOUND IN THE STANDARD.
 NO STRAIGHT LEG

[VIEW ONLINE](#)

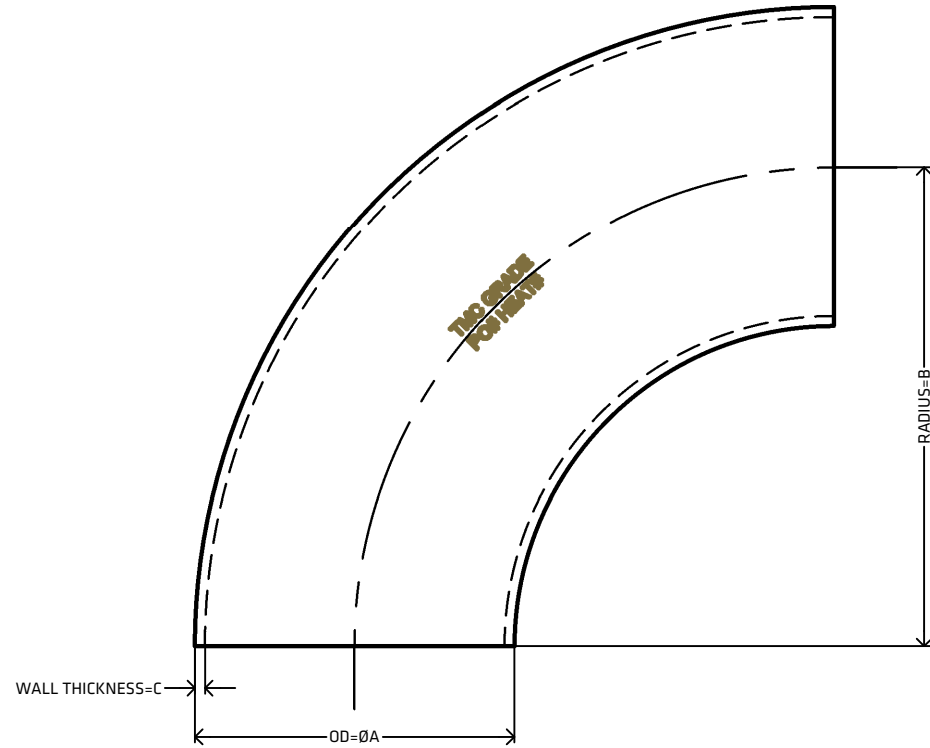

MEASUREMENTS

CODE	SIZE	INCH	GRADE	ØA	B	C
STB42590S	25.4	1"	304	25.4±0.12	38.1	1.6±0.16
STB43090S	31.8	1 1/4"	304	31.8±0.15	47.7	1.6±0.16
STB44090S	38.1	1 1/2"	304	38.1±0.19	57.0	1.6±0.16
STB45090S	50.8	2"	304	50.8±0.25	76.2	1.6±0.16
STB46590S	63.5	2 1/2"	304	63.5±0.31	95.0	1.6±0.16
STB47590S	76.2	3"	304	76.2±0.38	114.2	1.6±0.16
STB410090S	101.6	4"	304	101.6±0.5	152.4	1.6±0.16
STB420090S	203.2	8"	304	203.2±1.01	304.8	1.6±0.16
STB62590S	25.4	1"	316L	25.4±0.12	38.1	1.6±0.16
STB63090S	31.8	1 1/4"	316L	31.8±0.15	47.7	1.6±0.16
STB64090S	38.1	1 1/2"	316L	38.1±0.19	57.0	1.6±0.16
STB65090S	50.8	2"	316L	50.8±0.25	76.2	1.6±0.16
STB66590S	63.5	2 1/2"	316L	63.5±0.31	95.0	1.6±0.16
STB67590S	76.2	3"	316L	76.2±0.38	114.2	1.6±0.16
STB610090S	101.6	4"	316L	101.6±0.5	152.4	1.6±0.16
STB620090S	203.2	8"	316L	203.2±1.01	304.8	2.0±0.2



<p>THE METAL COMPANY TALK: 0508 304 316 VIEW: www.themetalcompany.co.nz TYPE: sales@themetalcompany.co.nz VISIT: 149 Alabama Rd, Blenheim 7201, NZ</p>	FILE	TMC-STB90S-SPEC-SHEET.DWG		CODE	STB90S	
	AUTHOR	CALEB G. - 10/08/23	STATUS	COMPLETE	SIZE	--
	CHECKED	BRENTLY F. - 11/08/23	SHEET	A4	DESC	TUBE BEND 90° SHORT RADIUS AS1528.3
	REV	1.0	SCALE	NOT TO SCALE		