

**NOTES & FEATURES**

MATERIAL: STAINLESS STEEL  
 GRADE: F316L  
 STANDARD: AS2129  
 MANUFACTURING PROCESS: FORGED TO ASTM A182  
 SURFACE FINISH: SPIRAL GROOVE  
 WORKING TEMPERATURE: SEE TABLE BELOW (\*)  
 WORKING PRESSURE: SEE TABLE BELOW (\*)

ERRORS & OMISSIONS EXCEPTED  
 ALL MEASUREMENTS IN MM UNLESS STATED OTHERWISE

FEATURES:  
 ALL SHARP EDGES HAVE BEEN CHAMFERED BY 0.5 MM AT 45°  
 BSP THREAD IS PARALLEL (BSPP)

(\*) MAXIMUM ALLOWABLE HYDROSTATIC TEST PRESSURE: 24 bar  
 -200°C to 100°C: 14 bar  
 150°C: 13 bar  
 200°C: 12 bar  
 250°C to 300°C: 11 bar  
 325°C: 10 bar  
 350°C: 9.5 bar  
 375°C: 9 bar  
 400°C: 8 bar  
 425°C: 7 bar

[VIEW ONLINE](#)

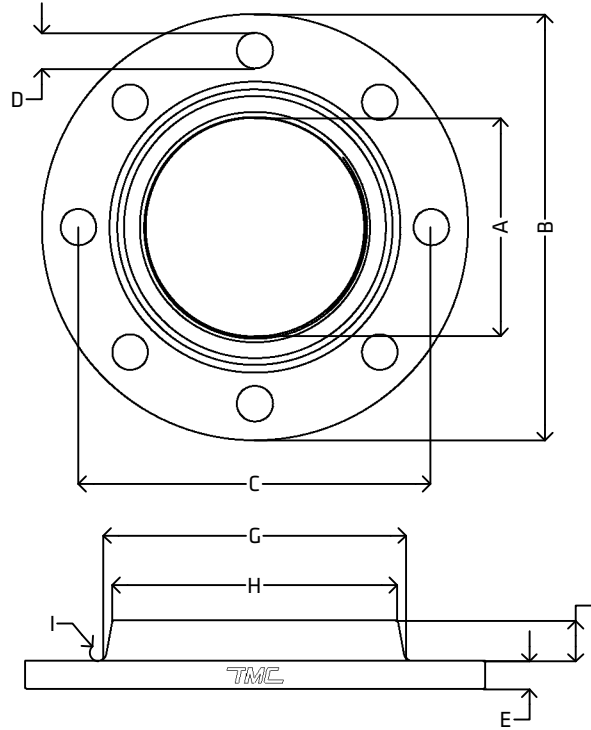

**DIMENSIONS**

CODE	METRIC	INCH	A	B	C	D	E	F	G	H	I
SBSPF15E	15NB	1/2"	1/2" BSPP	95.0	67.0 (±0.75)	4x14.0	10.0 (-0.5, +0.0)	10.0	38.0	33.0	2.0
SBSPF20E	20NB	3/4"	3/4" BSPP	100.0	73.0 (±0.75)	4x14.0	10.0 (-0.5, +0.0)	11.0	44.0	38.0	2.0
SBSPF25E	25NB	1"	1" BSPP	115.0	83.0 (±0.75)	4x14.0	10.0 (-0.5, +0.0)	11.0	52.0	48.0	2.0
SBSPF32E	32NB	1 1/4"	1 1/4" BSPP	120.0	87.0 (±0.75)	4x14.0	10.0 (-0.5, +0.0)	11.0	58.0	56.0	2.0
SBSPF40E	40NB	1 1/2"	1 1/2" BSPP	135.0	98.0 (±0.75)	4x14.0	10.0 (-0.5, +0.0)	13.0	70.0	62.0	2.0
SBSPF50E	50NB	2"	2" BSPP	150.0	114.0 (±0.75)	4x18.0	10.0 (-0.5, +0.0)	13.0	79.0	75.0	2.0
SBSPF65E	65NB	2 1/2"	2 1/2" BSPP	165.0	127.0 (±0.75)	4x18.0	10.0 (-0.5, +0.0)	16.0	93.0	90.0	2.0
SBSPF80E	80NB	3"	3" BSPP	185.0	146.0 (±0.75)	4x18.0	11.0 (-0.5, +0.0)	16.0	112.0	106.0	2.0
SBSPF100E	100NB	4"	4" BSPP	178.0	178.0 (±0.75)	8x18.0	13.0 (-0.5, +0.0)	19.0	140.0	133.0	4.0



<p><b>THE METAL COMPANY</b>                  TALK: 0508 304 316                  VIEW: www.themetalcompany.co.nz                  TYPE: sales@themetalcompany.co.nz                  VISIT: 149 Alabama Rd, Blenheim 7201, NZ</p>	FILE NAME TMC-SBSPFE.DWG		CODE SBSPF6E	SIZE 15NB (1/2") TO 100NB (4")
	AUTHOR CALEB G. - 29/01/24	FOR THE METAL COMPANY	DESCRIPTION STAINLESS STEEL BSP THREADED FLANGE TABLE E AS2129 ASTM A182 F316L	
	APPROVED BRENTLY F. - 23/02/24	CO. S. FISHER & SONS		
	REVISION 1.0	SHEET A4	SCALE NOT TO SCALE	